



Quick change tapping chucks **with** length compensation on compression and expansion
Mandrins de taraudage à changement rapide **avec** compensation longitudinale à la compression et traction



Verwendung:
Zur Aufnahme von Schnellwechsel-Ein-sätzen für Gewindebohrer.

Application:
For the chucking of quick change adaptors for taps.

Application:
Pour le serrage d'adaptateurs porte-tarands à changement rapide.

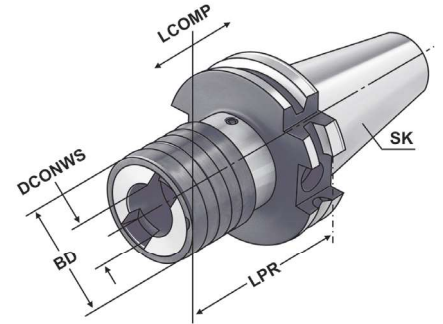

3

ISO 7388-1 DC	Form A		RFID Chip		13.04
---------------	--------	--	-----------	--	-------

Bestell-Nr. Order no. Référence	SK	Spannbereich Capacity Capacité	SZID	DCONWS	LPR	BD	LCOMP
DC.402.16.12	SK-DC 40	M3 - M14	1	19	63	36	7
DC.402.16.20	SK-DC 40	M5 - M22	2	31	97	53	12

Hinweis: Für Bearbeitungszentren ohne Synchronspindel.
Note: For machining centres without synchronous spindle.
Observation: Pour centres d'usinage sans broche synchrone.

